



featuring:

- Sliding magnetic porcelain whiteboard doors (lockable) with internal storage behind (3 adjustable shelves)
- Lower cupboards or tote tray bay options



assembly required.

- 2400mm wide units - supplied in three parts
- 3600mm wide units - supplied in eight parts

for safety reasons, we recommend that this unit is fixed to a wall.

options:

- Lockable lower cupboards (keyed alike)
- Tote tray bays or cupboards at either end of unit
- Three sizes:
 1. 2400w x 515d x 1900h (base unit 730h)
 2. 3600w x 515d x 1900h (base unit 730h)
 3. 3600w x 515d x 2070h (base unit 900h)
 (Size 3 has option for no internal shelves on left of unit, allowing space for a digital screen to be mounted behind sliding door.)

- Four colourways:



- Tote trays (additional)



- Variations of the Align Front of Class Unit: Additional drawers and custom sizes to meet your specifications. Speak to your nearest account manager for more information.

furnware[®]

range:



2400mmW x 1900mmH x 515mmD
Lower cupboards 730mmH

- 2 sliding whiteboards (lockable)
- 6 cupboards



2400mmW x 1900mmH x 515mmD
Lower cupboards 730mmH

- 2 sliding whiteboards (lockable)
- 4 cupboards
- 2 bays x 5h tote trays at each end of unit



2400mmW x 1900mmH x 515mmD
Lower cupboards 730mmH

- 2 sliding whiteboards (lockable)
- 1 open shelf on right end of unit
- 5 bays x 5h tote trays

** Sliding whiteboards not pictured*



3600mmW x 1900mmH x 515mmD
Lower cupboards 730mmH

- 2 sliding whiteboards (lockable)*
- 8 cupboards

** Sliding whiteboards not pictured*



3600mmW x 1900mmH x 515mmD
Lower cupboards 730mmH

- 2 sliding whiteboards (lockable)*
- 6 cupboards
- 2 bays x 5h tote trays at each end of unit

** Sliding whiteboards not pictured*



3600mmW x 1900mmH x 515mmD
Lower cupboards 730mmH

- 2 sliding whiteboards (lockable)*
- Single cupboard each end
- 8 bays x 5h tote trays

** Sliding whiteboards not pictured*



Tall unit
3600mmW x 2070mmH x 515mmD
Lower cupboards 900mmH

- 2 sliding whiteboards (lockable)*
- Screen space behind whiteboards
- 8 cupboards

** Sliding whiteboards not pictured*



Tall unit
3600mmW x 2070mmH x 515mmD
Lower cupboards 900mmH

- 2 sliding whiteboards (lockable)*
- 8 cupboards

** Sliding whiteboards not pictured*

align front of class unit - 2400 wide.

assembly instructions.



You have received **three** packages, including:

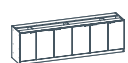

1 x Front of Class Unit Base

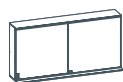

1 x Front of Class Unit Top



2 x Front of Class Unit Sides



12 x Surefix Screws - Square
24 x Titus Hilo Screws - Phillips



24 x Cover Caps



You will need:

Impact Driver
SQZ Driver bit □
Pozi Driver Bit +

Please note: If you have ordered multiple Front of Class Units, all three packages for the same unit will be identified with the same letter, (e.g. Unit A). Wall fixing hardware not included.

Step 1

Use multiple people to lift the Front of Class Unit Base to its final location. We recommend the unit is fixed to a wall for safety reasons.

Step 2

Use multiple people to lift the Front of Class Unit Top onto the Base, ensuring the sides and back of the Base and Top are flush and aligned.

Step 3

Fasten the Unit Top to the Unit Base by inserting the provided Surefix screws into the pre-drilled holes in the underside of the Unit Base rails and tightening.

Step 4

Fasten the Unit Sides to the pre-assembled Base and Top by inserting the Titus Hilo screws provided into the pre-drilled holes in the sides of each unit and fastening. Cover screw heads with the Cover Caps provided.

Steps 2 & 3

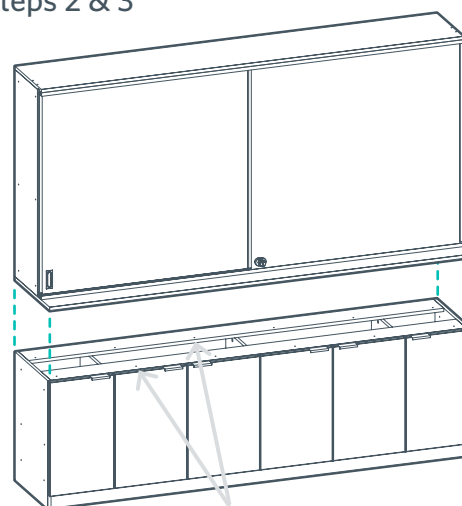

Insert 12 x Surefix screws in front and back rails

Step 4

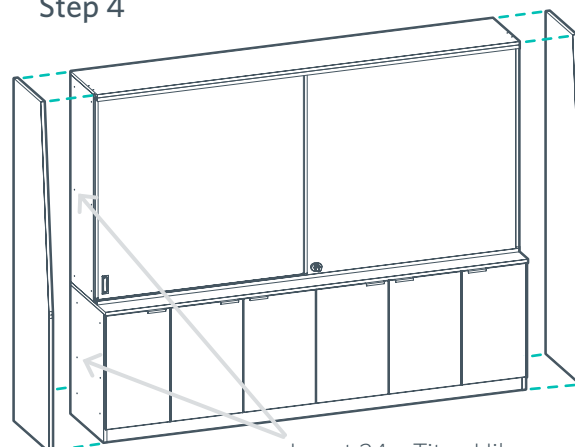

Insert 24 x Titus Hilo screws in both sides of the Unit Base and Top

align front of class unit - 3600 wide.

assembly instructions.

You have received **eight** packages, including:

You will need:



Impact Driver
SQZ Driver bit □
Pozi Driver Bit +

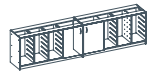

2 x Front of Class Unit Bases (A and B)

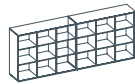

2 x Front of Class Unit Tops (A and B)



2 x Front of Class Unit Sides

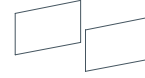

2 x Whiteboard Doors



1 x Top Aluminium track
2 x Bottom Aluminium tracks
4 x "L" Brackets (screwed into bottom track)



20 x Surefix Screws - Square
36 x Titus Hilo Screws - Phillips
40 x Whiteboard Screws - Square



36 x Cover Caps

Please note: If you have ordered multiple Front of Class Units, all eight packages for the same unit will be identified with the same letter, (e.g. Unit A). Wall fixing hardware not included.

Step 1

Position Front of Class Unit Bases A and B into their final location and fasten together with Titus Hilo screws, using pre-drilled holes.

Tip: Fix Front of Class Unit Bases to wall prior to step 2.

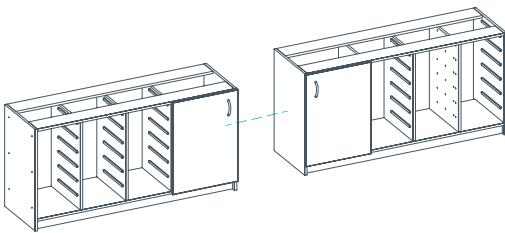

Step 2

Place Unit Tops A and B on top of the Unit Base, ensuring sides and back are aligned. Fasten together by screwing through the top of the Unit Base with Surefix screws, using pre-drilled holes.

Tip: Fix Front of Class Unit Tops to wall prior to step 3.

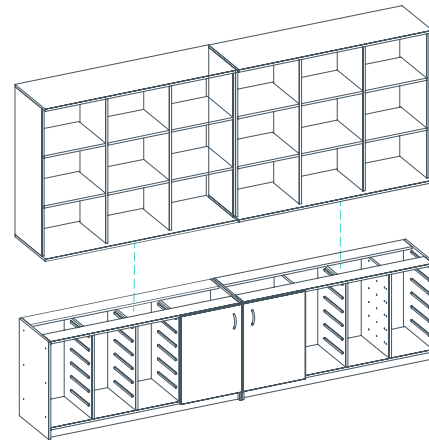

Step 3

Screw aluminium track into place with Whiteboard screws, using pre-drilled holes (highlighted red items in drawing).

Slide Whiteboard Doors onto tracks, ensuring lockable door is at the front.

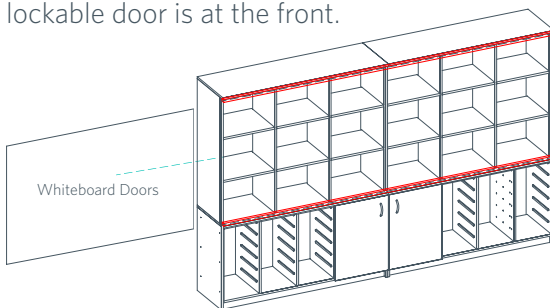

Step 4

Once Whiteboard Doors are in place, screw on both Unit Sides using pre-drilled holes with 24 x Titus Hilo Screws. Cover screw heads with Cover Caps.

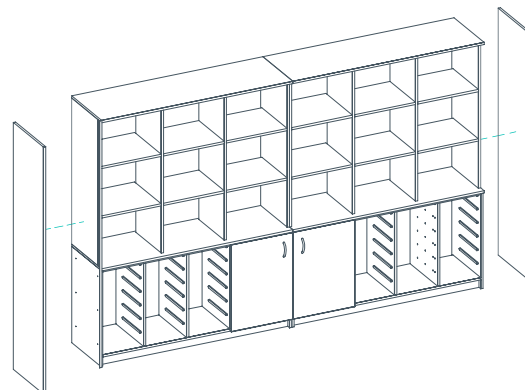

get in touch.



rebecca king
+64 27 337 9539
rebecca.king@furnware.com



ezra murray
+64 27 464 0086
ezra.murray@furnware.com



tim curtis
+64 21 482 298
tim.curtis@furnware.com



marianne elliott
+64 27 753 302
marianne.elliott@furnware.com



ian johnstone
+64 21 382 239
ian.johnstone@furnware.com



kyle cooke
+64 27 627 4261
kyle.cooke@furnware.com

